



ST-MAK or SRV-MAK Series Voltage Stabilizer

800kVA / 640kW Input $\pm 20\%$ & $\pm 10\%$
Three Phase Servo & Static Voltage Stabilizer



MAK+
POWER SYSTEMS

www.mak-powersis.de

- Electronic Controlled New Generation Stabilizer, Air Cooled
- Each Phase Automatically Controlled
- Thyristor Technology with 1 Millisecond Response Time
- Micro Chip Controlled, Fast and Precisely
- No effect on the Load from Voltage Stabilizer
- High Input Power Factor (>0.99)
- High Efficiency up to 98%
- Optional Dual Input
- Wide Input Voltage Range
- Advanced Protection and Data Logging
- Short Circuit and Overload Protection
- Unlimited Number of Paralleled Modules
- Selectable Output Voltage Values
- Made in Europe User Internal Materials
- Manual Bypass Operation
- Over Voltage and Low Voltage Protection
- Small Footprint and Easy Maintenance
- Advanced Communication Capabilities
- Perfect Generator Compatibility
- Customizable with Power Supply with Batteries & Inverter



Special Applications



Outdoor Solutions



Customized Solutions

*800kVA





ST-MAK or SRV-MAK Series Voltage Stabilizer

800kVA / 640kW

General Information of the Static Voltage Stabilizers

MAK 
POWER SYSTEMS

www.mak-powersis.de



STATIC VOLTAGE STABILIZER

ST-Mak Static Voltage Stabilizer; are the devices of microprocessor voltage control protection and management which are controlled, and which have high speed semiconductor technology. They are adjusted to the right voltage value required by industrial devices that are fastly growing and that are becoming more sensitive; and they are designed to meet their continuous, settled and secure energy needs.



Nowadays, thousands of users who have totally different characteristics such as plants, hospitals, public buildings, houses, farms, constructions etc. use the same main grid. Mak Static Voltage Stabilizer optimizes the irregular electricity which different users receive from city main grid at the same time, in accordance with only your business and the electronic devices you use.

ST-Mak Static Voltage Stabilizer which can be produced in a very wide input voltage interval for places where grid voltages drop or rise excessively; evaluates grid voltage decreases and increases in 0.020 seconds when the main grid voltage drops -60% or rises +%40 and corrects with 500V/sec. Speed. By this means, your expensive industrial devices are protected against dangerous voltage changes and also it enables your systems to work with high efficiency and without interruption.

ST-Mak Static Voltage Stabilizer is developed to solve the technical problems the users experience with Thyristor Type Voltage Regulators with electronic/ trafo structure which are widely used. Motor-chain systems used in electro-mechanic voltage regulators work slowly and this can not prevent many electronic devices from being affected by voltage decreases. With its microprocessor controlled semiconductor power control system, Mak Static Voltage Stabilizer works 10 times more faster than electro-mechanic systems.

Brush-coal system which is used for transferring power in electro-mechanic regulators are not applicable for dusty and damp industrial environments and requires periodic maintenance. Semiconductor thyristor units used in Mak Static Voltage Stabilizer work in every kind of industrial environment without being affected by damp and without requiring maintenance. High energy losses arise because of large scale transformers and variac systems used in electro-mechanic systems. By using thyristor units in Mak Static Voltage Stabilizer, energy losses are reduced to 2%.

ST-Mak Static Voltage Stabilizer has High Voltage, Low Voltage, Over-temperature, Overload, Short Circuit and Phase Break protections for its own operating safety and also for all electronic devices in your business to work safely. There is a working safety. It is equipped with thermomagnetic fuses in its inputs and outputs.

ST-MAK Static Voltage Stabilizer is designed with its compact, esthetic and modular structure, in such a way that it can be easily connected with electric systems everywhere in the world. "BUS-BAR PANEL INPUT-OUTPUT MODULE" which is required for direct connection can be added to BUS BAR systems optionally on request.

Information such as Input Voltage, Output Voltage, and Load Amount etc. can be viewed; breakdown and warning information can be followed on LCD DISPLAY which is standard in Mak SVS. One may reach devices over on the web, view all information on LCD DISPLAY and change set values of the device with "REMOTE VIEWING AND MANAGEMENT".



SRV-MAK Series Voltage Stabilizer

800kVA / 640kW

General Information of the Servo Voltage Stabilizers

MAK 
POWER SYSTEMS

www.mak-powersis.de



SERVO VOLTAGE STABILIZER

SRV-Mak Servo Voltage Stabilizer; are the devices of microprocessor voltage control protection and management which are controlled, and which have high speed servo technology. They are adjusted to the right voltage value required by industrial devices that are quick growing and that are becoming more sensitive; and they are designed to meet their continuous, settled and secure energy needs.

Nowadays, thousands of users who have totally different characteristics such as plants, hospitals, public buildings, houses, farms, constructions etc. use the same main grid. Mak Servo Voltage Stabilizer optimizes the irregular electricity which different users receive from city main grid at the same time, in accordance with only your business and the electronic devices you use.

SRV-Mak Servo Voltage Stabilizer which can be produced in a very wide input voltage interval for places where grid voltages drop or rise excessively; evaluates grid voltage decreases and increases in 0.1 seconds when the main grid voltage drops -60% or rises +%40 and corrects till 100V/sec. Speed. By this means, your expensive industrial devices are protected against dangerous voltage changes and also it enables your systems to work with high efficiency and without interruption.

SRV-Mak Servo Voltage Stabilizer is developed to solve the technical problems the users experience with Variac Type Voltage Regulators with electro-mechanic structure which are widely used. Motor-chain systems used in electro-mechanic voltage regulators work slowly and this can not prevent many electronic devices from being affected by voltage decreases. With its microprocessor controlled Servo power control system, Mak Servo Voltage Stabilizer works 10 times more faster than old solutions and systems.

Brush-coal system which is used for transferring power in electro-mechanic regulators are applicable for dusty and damp industrial environments and requires periodic maintenance. Servo controlled units used in Mak Servo Voltage Stabilizer work in every kind of industrial environment without being affected by damp and without requiring maintenance. High energy losses arise because of large scale transformers and variac systems used in electro-mechanic systems. By using Servo toroid transformer units in Mak Servo Voltage Stabilizer, energy losses are reduced to 2%.

SRV-Mak Servo Voltage Stabilizer has High Voltage, Low Voltage, Over-temperature, Overload, Short Circuit and Phase Break protections for its own operating safety and also for all electronic devices in your business to work safely. There is a working safety. It is equipped with thermo-magnetic fuses in its inputs and outputs.

SRV-MAK Servo Voltage Stabilizer is designed with its compact, esthetic and modular structure, in such a way that it can be easily connected with electric systems everywhere in the world. "BUS-BAR PANEL INPUT-OUTPUT MODULE" which is required for direct connection can be added to BUS BAR systems optionally on request.

Information such as Input Voltage, Output Voltage, and Load Amount etc. can be viewed; breakdown and warning information can be followed on LCD DISPLAY which is standard in Mak SVS. One may reach devices over on the web, view all information on LCD DISPLAY and change set values of the device with "REMOTE VIEWING AND MANAGEMENT".



ST-MAK or SRV-MAK Series Voltage Stabilizer

800kVA / 640kW Three Phase General Information of the Stabilizers



Capacity	800 kVA
Power Watt	640 kW
INPUT	
Input Voltage Range	Selectable From Screen: 380V or 400V or 415V 3P+N+PE
Input Power Factor	At Full Load >0.99
Voltage Range	Option 1: "-%15 / + %15" & Option 2: "-%20 / + %15" & Option 3: "-%25 / + %15"
Technology Servo & Thyristor	Servo & Thyristor
Output Current Values	Output and Input Nominal Voltage @400Volt Input Current is maximum 924A "Option 1: %-15 @340V Input=>Output Current 803A ==> Output 555kW" "Option 2: %-20 @320V Input=>Output Current 770A==> Output 533kW" "Option 3: %-25 @300V Input=>Output Current 739A==> Output 511kW"
OUTPUT	
Output Voltage Range	Selectable From Screen: 380V or 400V or 415V or 480V 3P+N+PE "Optional 230V or 480V or 690V
Protection	Over Current, Over Voltage, Low Voltage, Over Power, Over Temperature, Short Circuit
Efficiency	Minimum %97 and up to 98,5%
Output Frequency Range	Same as Input / Input Frequency Range Protection
THD (THDv)	No Harmonic Distortion Creation / Passive Harmonic Filter is Optional
Regulation Speed	Servo: 200V/Second & Static: 500V/Second
Crest Factor (CF)	3:1
Overload Capacity*	At 125% Load 1min, at 150% Load 1 Second
COMMUNICATION	
Communication Port	Standard: RS232 Standart , SNMP Adapter Option & Dry Contact Card
Control Cards	Optional: RS485. Dry Contact Card, External Monitoring Screen
Protocol	Optional: SEC, TELNET,
STANDARDS	
Quality	ISO 9001 - ISO 14001 - ISO 18001
Performance	EN62040 -3 (VFI-SS-111)
EMC/LVD	EN62040 - 2 / EN62040 -1 EN60950
GENERAL	
Running Temperature	Standard: 0°C~50°C & " With degradation @55°C Power Loss %30 & @60°C %60
Storage Temperature	0°C ~50°C
Protection Class	Standard IP20 , Optional IP23 , IP43, IP44, IP55
Chassis & Humidity	Static Paint & Anti-Rust Protection & 0-95%
Screen	" Standard 100mm x 100mm, Optional Touch Screen 40x200, Customized Touch LCD Screen & English, German
Altitude	<1000Meter @35°C & <1500Meter @30°C & after 1500Meter for Each Meter %1 Loss
Alerts	500 Event Logs & 20 Parameters for Each Log "As Excel Sheet"
Parallel Operation	Paralleling is impossible / Only possible with Power Conditioner it is an other technology
EPO (Emergency Power Off)	Standard EPO / External Protection Values
Isolation Transformer	Optional for Both Side If Needed
Net Weight (kg)	Servo: 2900kg & Pack: 3100kg / Static: 2100kg Pack: 2200kg
Dimensions (WxDxH) (mm)	Servo: 3x70cmx195x190 cm & Pack: 3x76 x 205x215 cm / Static: 3x62x135x172 cm Pack: 3x67cmx 140cmx185cm

*under certain conditions

We can Adjust the Poco, Pleas Let Us Know If You Have a Special Dimensions

* 3 Phase in / 1 Phase Out Version is Available. (10 to 30kVA)

Mak Plus Power Systems UG reserves the right to change or modify product design, construction, specifications, or materials without prior notice and without incurring any obligation to make such changes and modifications on Mak Plus Power Systems UG products previously or subsequently sold. Mak PP Systems does not guarantee the items of the accuracy and completeness.



ST-MAK Series Voltage Stabilizer

Single Line Diagram

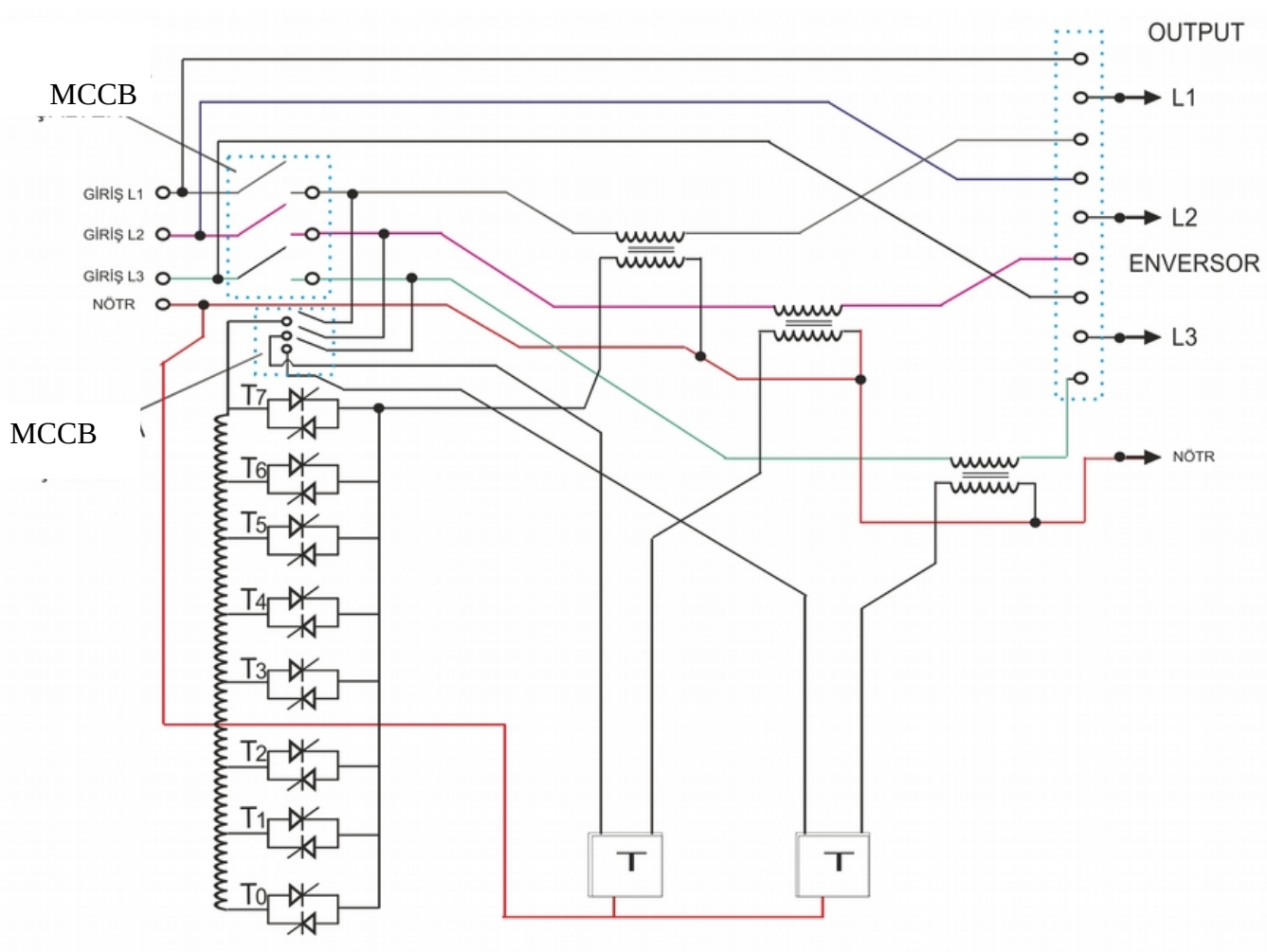



SRV-MAK Series Voltage Stabilizer

Single Line Diagram



SERVOREG

